

CREATED DATE

16/2/22

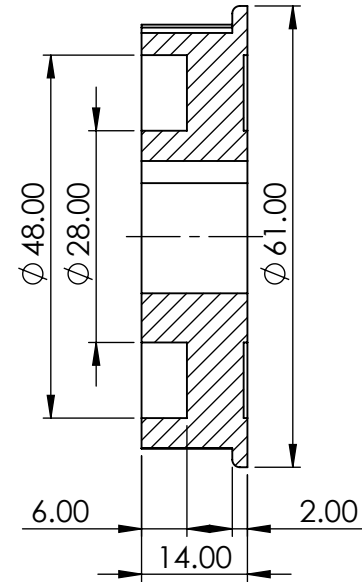

SECTION B-B

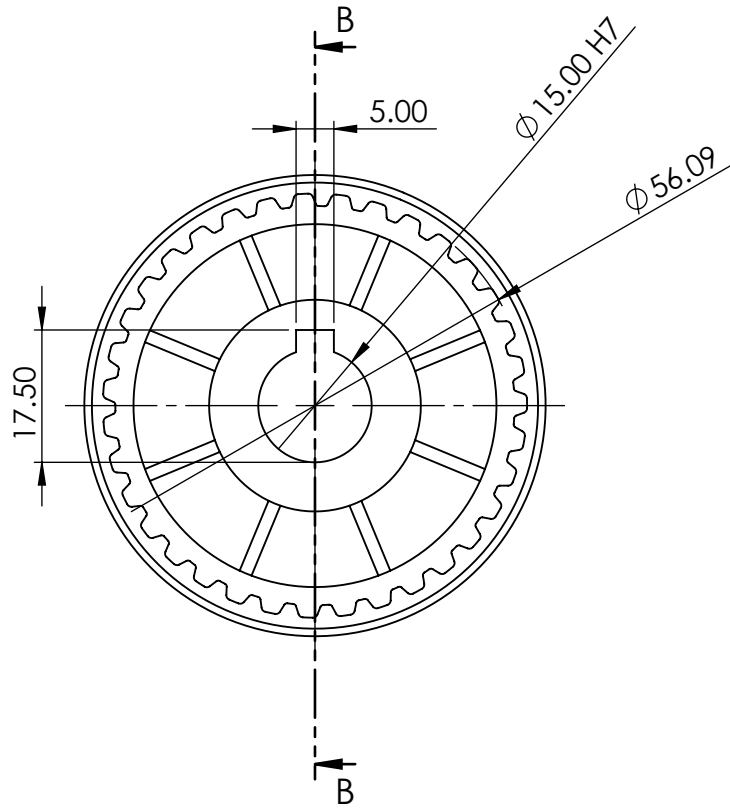
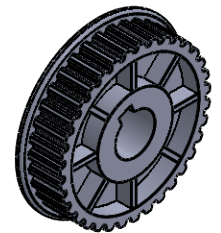

GENERAL TOLERANCE'S FOR DIMENSIONS AND FORM POSITION (Ref. ISO 2768 sk)

DEVIATIONS FOR RADI AND CHAMFERS  
RANGE OF NOMINAL DIMENSIONS

DEVIATIONS FOR GEOMETRY

NAME	DATE
DRAWN MANOJ	16/2/22
CHK'D MILLIND	16/2/22
APPVD KARVE	16/2/22

TUFF PLAST PUNE PVT. LTD.

DATE REVISION

MODEL NAME

35XL 'A' TYPE

DWG NO./PART NO. XL-035-A-PRT-H-16.22

SHEET 1 OF 1

	DEVIATIONS FOR LINEAR DIMENSIONS								DEVIATIONS FOR ANGULAR DIMENSIONS				
	RANGE OF NOMINAL DIEMENSIONS								RANGE OF NOMINAL DIEMENSIONS				
ABOVE	0.5	3	6	30	120	315	1000	2000	ABOVE	-	10	50	120
UPTO	3	6	30	120	315	1000	2000	4000	UPTO	10	50	120	-
TOL.	±0.1	±0.1	±0.2	±0.3	±0.5	±0.8	±1.2	±2	TOL.	±1°	±30'	±20'	±10'

	RANGE OF NOMINAL DIMENSIONS					
	ABOVE	10	30	100	300	1000
UPTO	10	30	100	300	1000	
TOL.	±0.2	±0.5	±1	±2	±3	

PROPRIETARY & CONFIDENTIAL  
THE INFORMATION CONTAINED IN THIS  
DRAWING IS THE SOLE PROPERTY OF  
TUFFPLAST ANY REPRODUCTION IN PART IS  
PROHIBITED.

MATERIAL:  
WEIGHT: Gram  
DO NOT SCALE

IF IN DOUBT, ASK

A4