

CREATED DATE

15/2/22

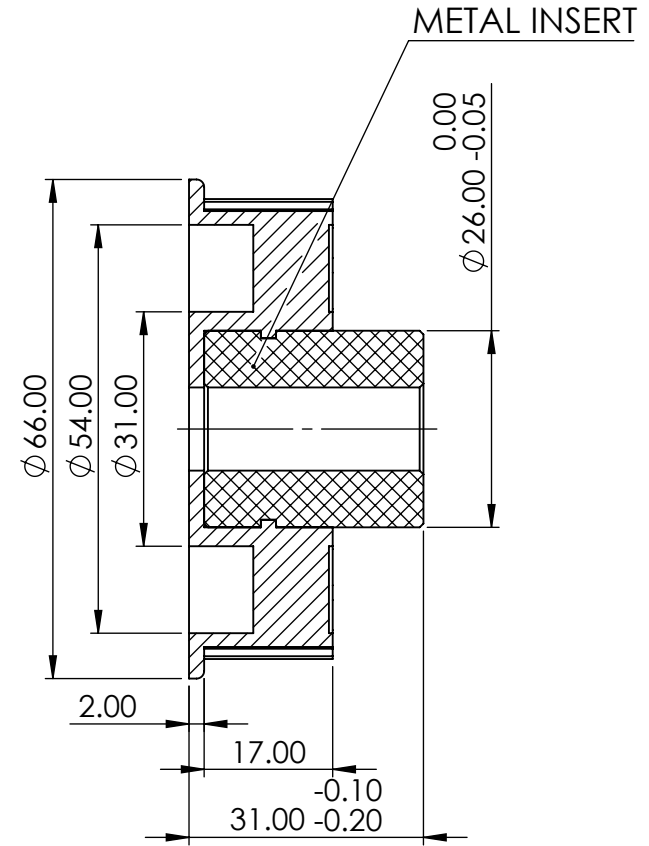
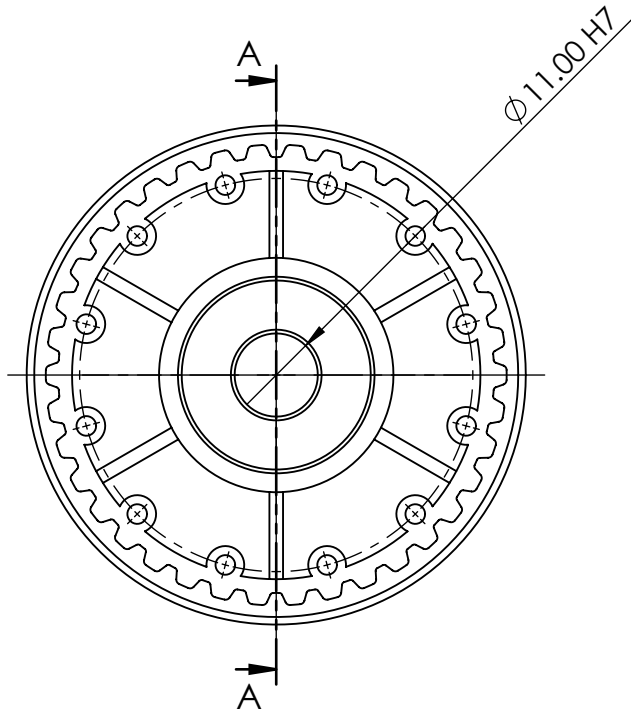

SECTION A-A

GENERAL TOLERANCE'S FOR DIMENSIONS AND FORM POSITION (Ref. ISO 2768 sk)

	DEVIATIONS FOR LINEAR DIMENSIONS				DEVIATIONS FOR ANGULAR DIMENSIONS			
	RANGE OF NOMINAL DIEMENSIONS				RANGE OF NOMINAL DIEMENSIONS			
ABOVE	0.5	3	6	30	120	315	1000	2000
UPTO	3	6	30	120	315	1000	2000	4000
TOL.	±0.1	±0.1	±0.2	±0.3	±0.5	±0.8	±1.2	±2

DEVIATIONS FOR RADI AND CHAMFERS

RANGE OF NOMINAL DIMENSIONS	RANGE OF NOMINAL DIMENSIONS			
	0.5	3	6	30
TOL.	±0.2	±0.5	±1	±2

DEVIATIONS FOR GEOMETRY

	RANGE OF NOMINAL DIMENSIONS					
	ABOVE	10	30	100	300	1000
UPTO	10	30	100	300	1000	3000
—	0.05	0.1	0.2	0.4	0.6	0.8
—	0.4	0.4	0.4	0.6	0.8	1
—	0.6	0.6	0.6	0.6	0.8	1
—	0.2	0.2	0.2	0.2	0.2	0.2

NAME	DATE
DRAWN MANOJ	15/2/22
CHK'D TUKARAM	15/2/22
APP'VD KARVE	15/2/22

TUFF PLAST PUNE PVT. LTD.

DATE REVISION

MODEL NAME

38XL PULLEY

DWG NO./PART NO.

XL-038-B-PRT-H-15.22

PROPRIETARY & CONFIDENTIAL
THE INFORMATION CONTAINED IN THIS
DRAWING IS THE SOLE PROPERTY OF
TUFFPLAST ANY REPRODUCTION IN PART IS
PROHIBITED.

MATERIAL:
WEIGHT: Gram
DO NOT SCALE

A4

SHEET 1 OF 1