

CREATED DATE

25/2/22

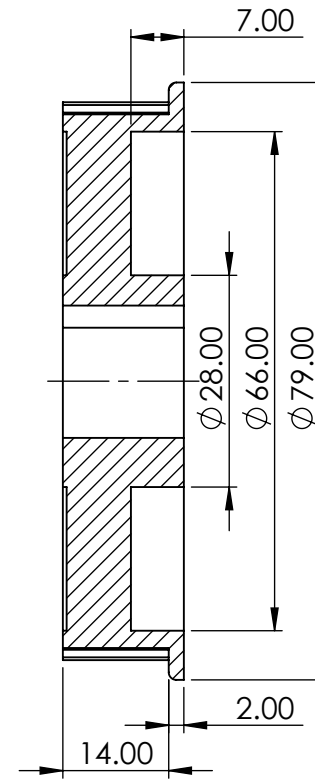
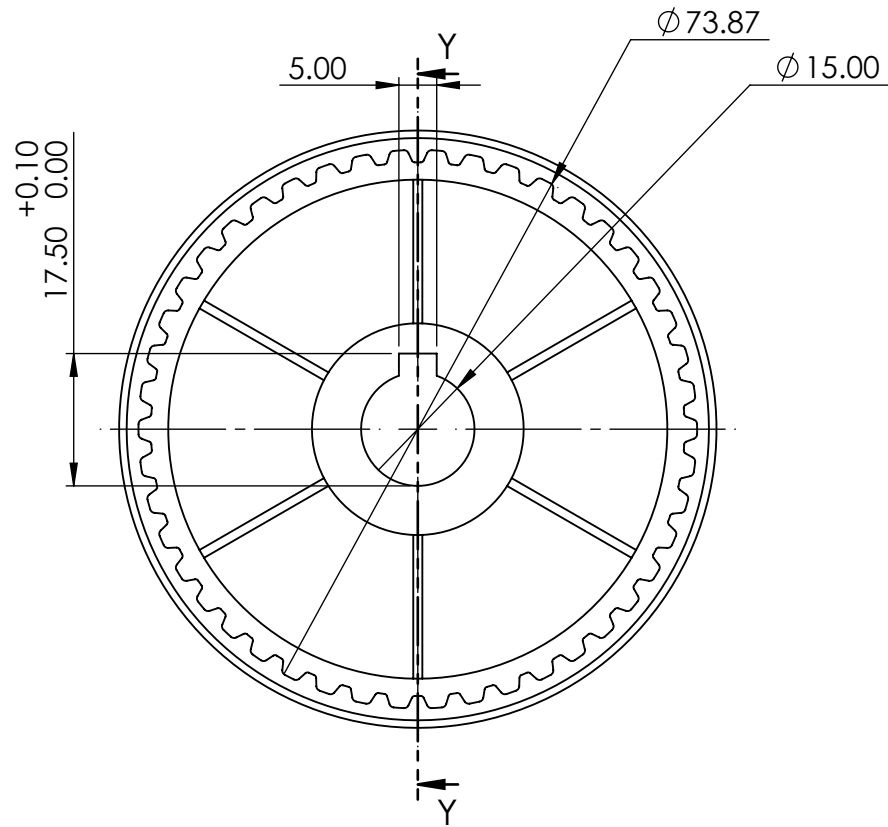

SECTION Y-Y

GENERAL TOLERANCE'S FOR DIMENSIONS AND FORM POSITION (Ref. ISO 2768 sk)

DEVIATIONS FOR RADI AND CHAMFERS
RANGE OF NOMINAL DIMENSIONS

DEVIATIONS FOR GEOMETRY

NAME	DATE
DRAWN MANOJ	25/2/22
CHK'D MILLIND	25/2/22
APPVD KARVE	25/2/22

TUFF PLAST PUNE PVT. LTD.

DATE REVISION

MODEL NAME

46XL 'A' PULLEY

DWG NO./PART NO. XL-046-A-PRT-H-25.22

SHEET 1 OF 1

	DEVIATIONS FOR LINEAR DIMENSIONS					DEVIATIONS FOR ANGULAR DIMENSIONS							
	RANGE OF NOMINAL DIEMENSIONS					RANGE OF NOMINAL DIEMENSIONS							
ABOVE	0.5	3	6	30	120	315	1000	2000	ABOVE	-	10	50	120
UPTO	3	6	30	120	315	1000	2000	4000	UPTO	10	50	120	-
TOL.	±0.1	±0.1	±0.2	±0.3	±0.5	±0.8	±1.2	±2	TOL.	±1°	±30'	±20'	±10'

DEVIATIONS FOR RADI AND CHAMFERS RANGE OF NOMINAL DIMENSIONS				
	0.5	3	6	30
	3	6	30	120
TOL.	±0.2	±0.5	±1	±2

	DEVIATIONS FOR GEOMETRY					
	ABOVE	10	30	100	300	1000
UPTO	10	30	100	300	1000	3000
—□	0.05	0.1	0.2	0.4	0.6	0.8
≡	0.4	0.4	0.4	0.6	0.8	1
≡	0.6	0.6	0.6	0.6	0.8	1
↗	0.2	0.2	0.2	0.2	0.2	0.2

PROPRIETARY & CONFIDENTIAL
THE INFORMATION CONTAINED IN THIS
DRAWING IS THE SOLE PROPERTY OF
TUFFPLAST ANY REPRODUCTION IN PART IS
PROHIBITED.

MATERIAL:
ARNITE
WEIGHT: 38.31 Gram
DO NOT SCALE

6

5

4

3

2

1

A

A

A4