

4

3

2

1

F

F

E

E

D

D

C

C

B

B

A

A

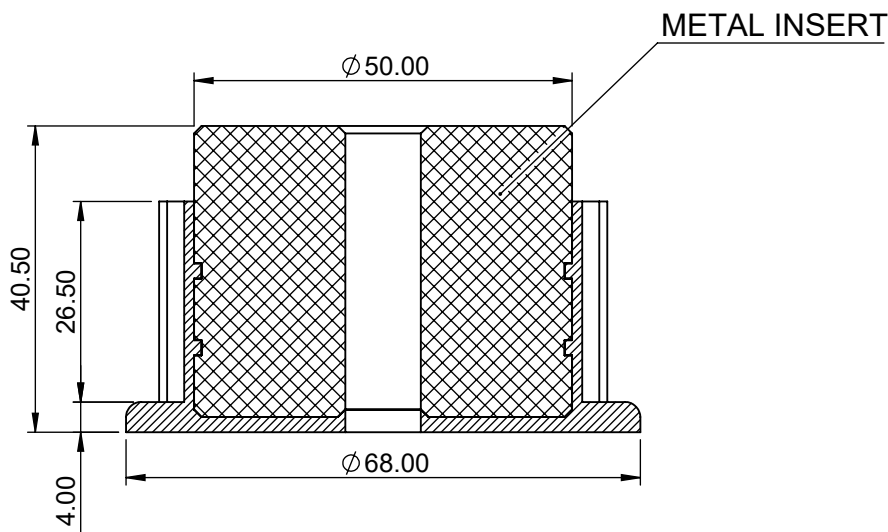
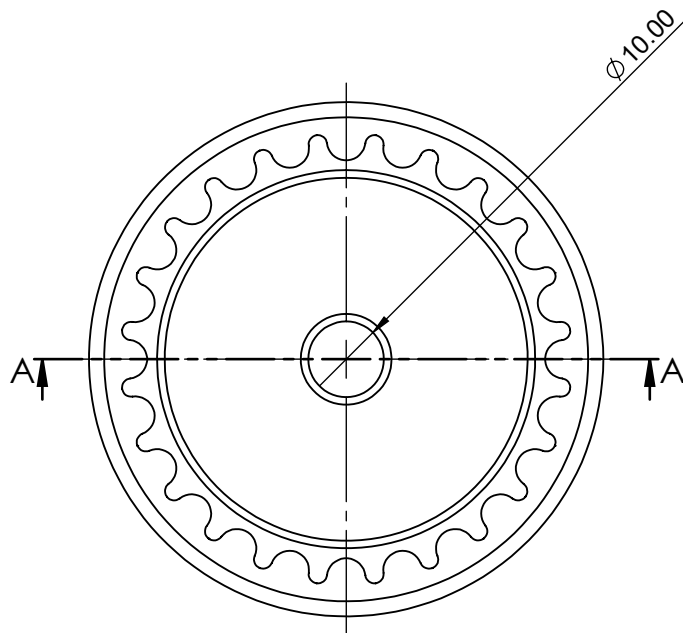

SECTION A-A

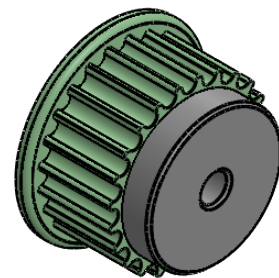

GENERAL TOLERANCES FOR DIMENSIONS AND FORM POSITION (Ref. ISO 2768 sk)

DEVIATIONS FOR LINEAR DIMENSIONS		DEVIATIONS FOR ANGULAR DIMENSIONS	
RANGE OF NOMINAL DIMENSIONS		RANGE OF NOMINAL DIMENSIONS	
ABOVE	0.5 3 6 30 120 315 1000 2000	ABOVE	- 10 50 120
UPTO	3 6 30 120 315 1000 2000 4000	UPTO	10 50 120 -
TOL	±0.1 ±0.2 ±0.3 ±0.5 ±0.8 ±1.2 ±2	TOL	±1* ±30* ±20' ±10'

DEVIATIONS FOR RADI AND CHAMFER

RANGE OF NOMINAL DIMENSIONS	
0.5 3 6 30	UPTO
3 6 30 120	UPTO
TOL ±0.2 ±0.5 ±1 ±2	
IF IN DOUBT, ASK	

DEVIATIONS FOR GEOMETRY

ABOVE	10	30	100	300	1000
UPTO	10	30	100	300	1000 3000
UPTO	0.05	0.1	0.2	0.4	0.6 0.8
UPTO	0.4	0.6	0.8	0.8	1
UPTO	0.6	0.6	0.6	0.8	1
UPTO	0.2	0.2	0.2	0.2	0.2



DATE	REVISION	SHEET 1 OF 1
PROPRIETARY & CONFIDENTIAL THE INFORMATION CONTAINED IN THIS DRAWING IS THE SOLE PROPERTY OF TUFFPLAST ANY REPRODUCTION IN PART IS PROHIBITED.		

NAME	DATE
DRAWN MANOJ	30/5/22
CHK'D TUKARAM	30/5/22
APPV'D MILLIND	30/5/22
MATERIAL:	

MODEL NAME:- 24-8M PULLEY	DO NOT SCALE
DWG NO.-: 24-8M PULLEY	

WEIGHT: Gram	A4
--------------	----

4

3

2

1